

MATHIUS SHADOW-SKY

ON - TENSIONION - T

MUSIQUE DU CORPS SUR LUI-MÊME

**Posture**  
**Mouvement**  
 Immobile Debout Raide  
 Le regard fixe droit devant  
 Prêt à jouer, baguettes posées sur les peaux des toms

**PERCUSSION**

**Circulation du sang**  
**Respiration**  
**Battements du cœur**

Poumons vides retenus  
 • 7; 7; 7; 7; 7; 7; forcé, nasal

*7°*

*micro sur intestin (stéthoscope)*  
*très lent*  
*micro sur la gorge*  
*micro sous le nez*  
*micro sur le cœur*  
*micro devant la bouche*

Contractions

Très lent et très progressif

Debut des contractions

(Vitrès) + bac de graviers

Enfoncement

Pieds

+ bac de sable

3p frisson de frottage

Chevilles

4p Enfoncement

Jambes

**Posture**  
**Mouvement**  
 Vide Immobile Debout Raide  
 Le regard fixe droit devant  
 Prêt à jouer  
 Totalemtent détendu

**CONTREBASSE**

**Circulation du sang**  
**Respiration**  
**Battements du cœur**

l'archet posé sans bruit sur la corde

Silence total

On ne voit pas l'archet bouger

Son très lointain

Son harmonique pur lisse + Sourdine

Pratiquement imperceptible

lache, nasal

forcé

lache

forcé

lache

**Posture**  
**Mouvement**  
 Vide Immobile Debout Droit  
 Le regard fixe droit devant  
 Prêt à jouer  
 Totalemtent détendu

**VIOLON**

**Circulation du sang**  
**Respiration**  
**Battements du cœur**

l'archet posé sans bruit sur la corde

Silence total

On ne voit pas l'archet bouger

Calme total

Son absent

Son harmonique pur lisse + Sourdine

Pratiquement imperceptible

lache, nasal

**Eclairage**

NOIR

10.20



Vite + bac de graviers + bac de sable

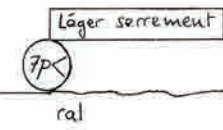
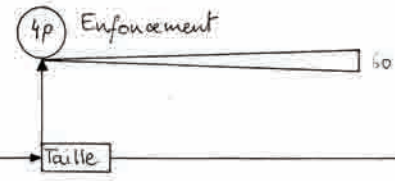
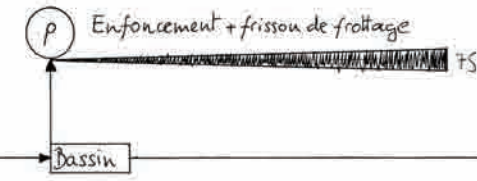

Mouvements très lents  
Enlevez la sourdine  
a tempo

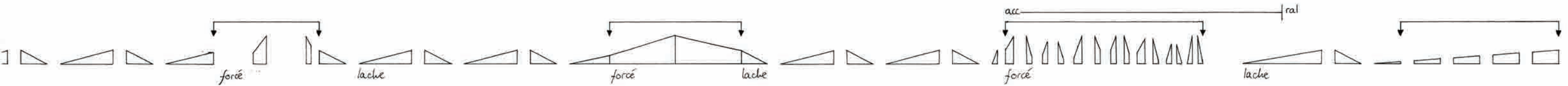

Mouvements trop lents  
Enlevez la sourdine



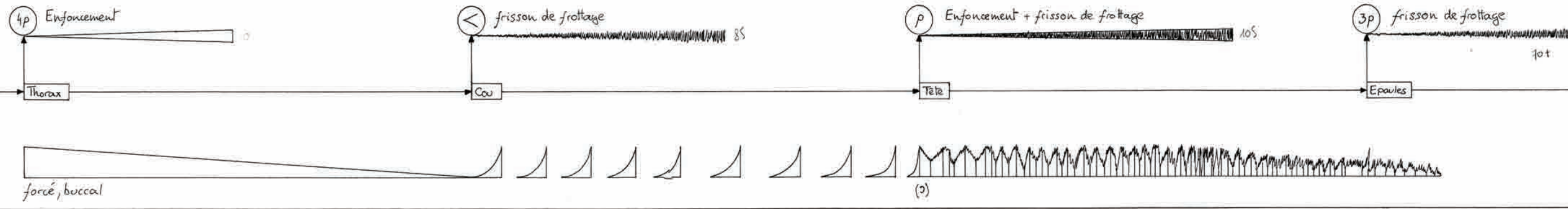

Angoisse  
6p<  
ral. acc. a tempo

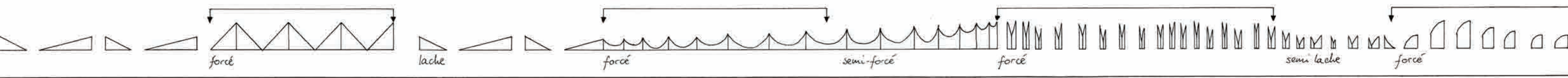

Le son se remplit  
6p< 5p<

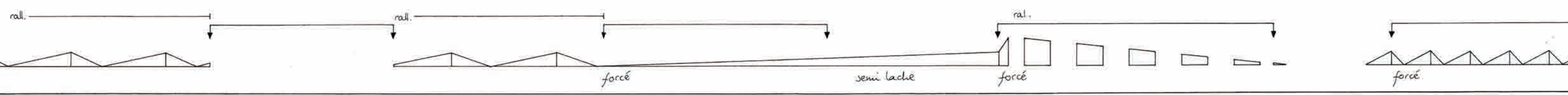

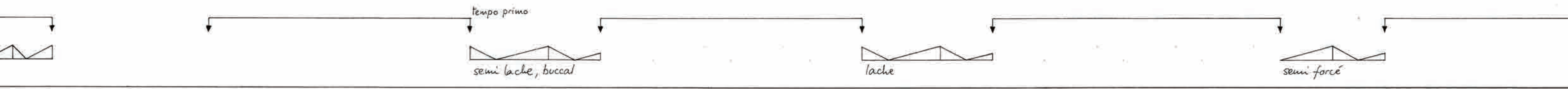
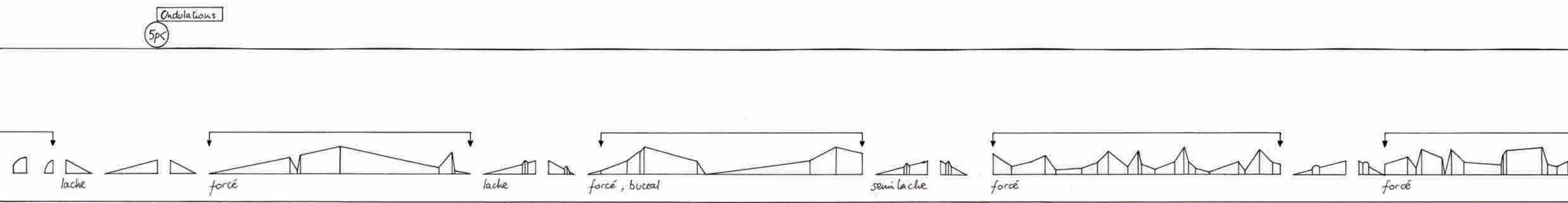
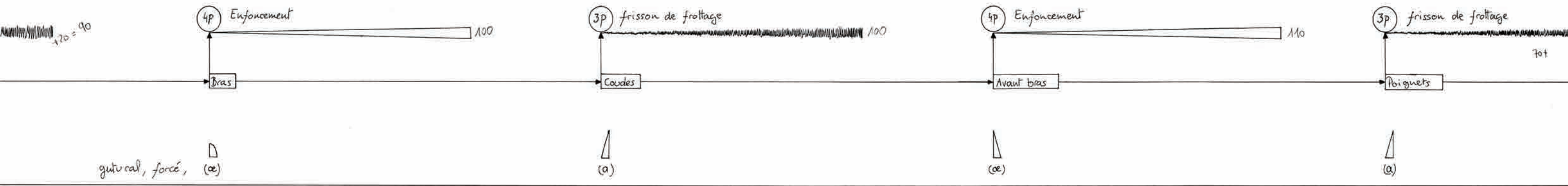

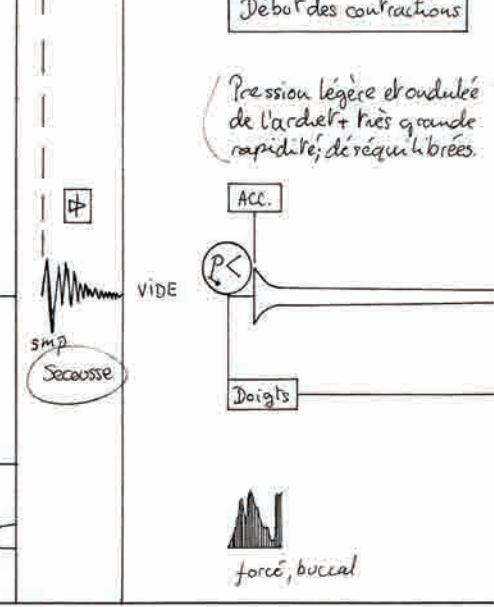
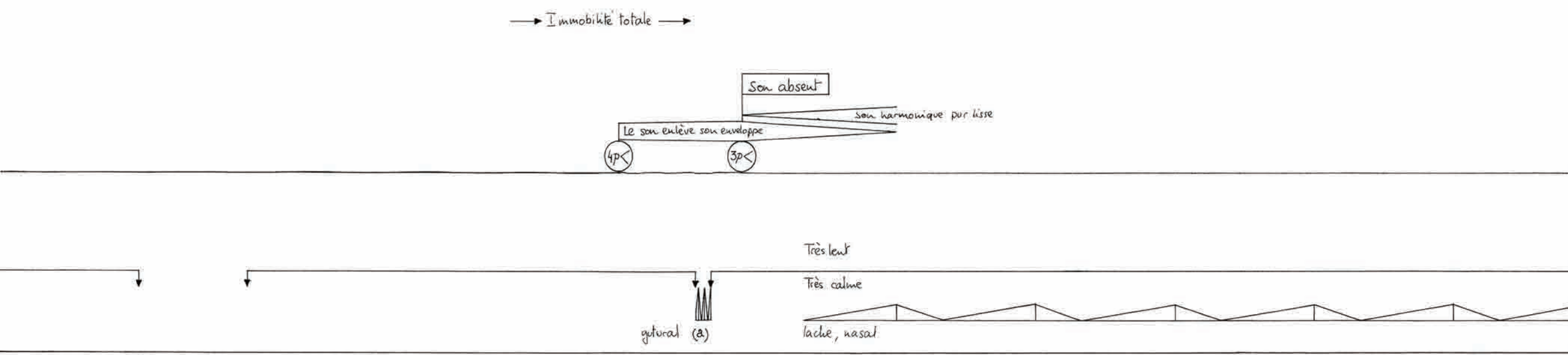
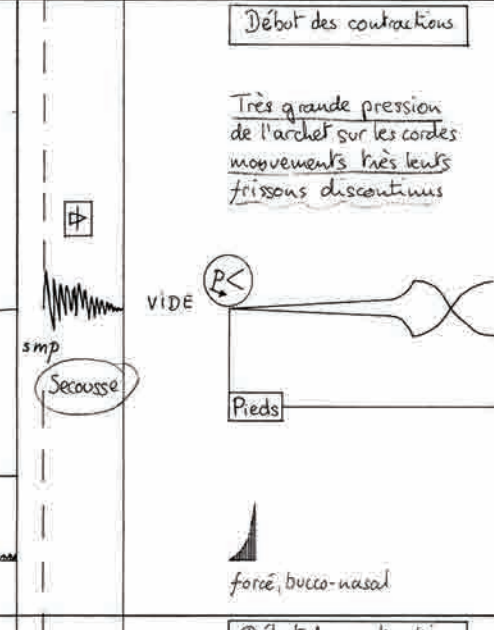
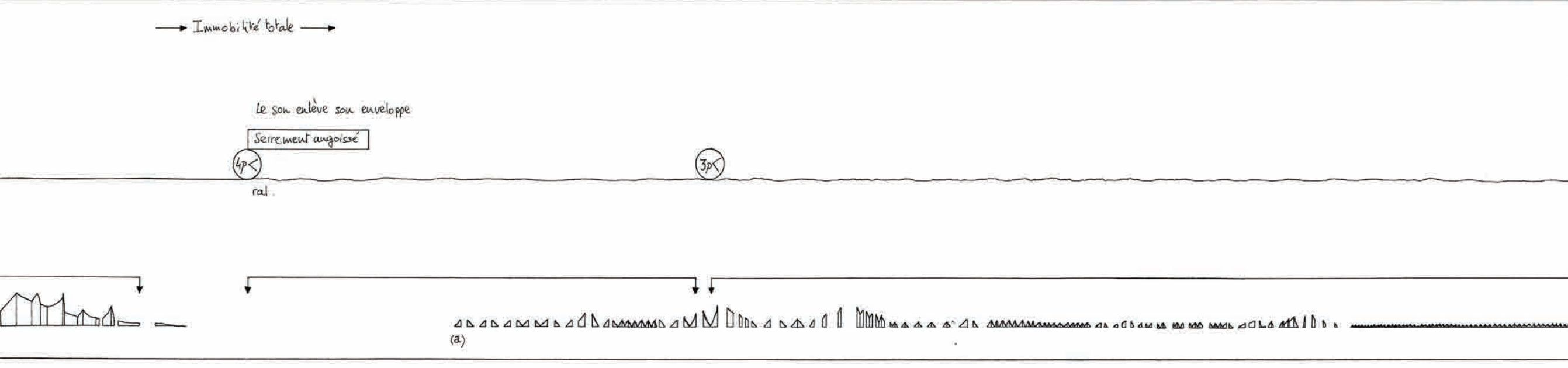
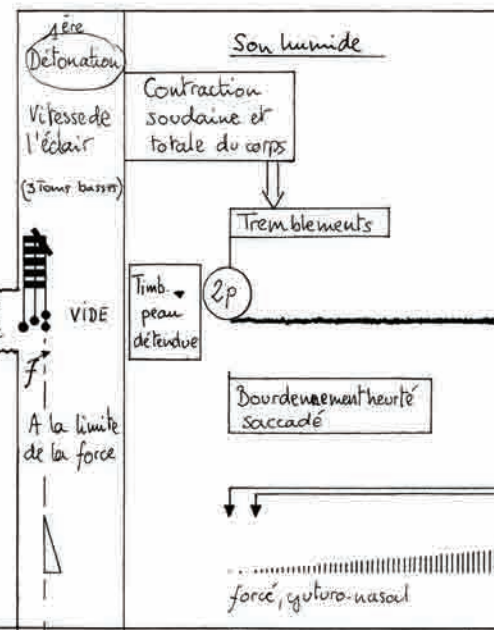
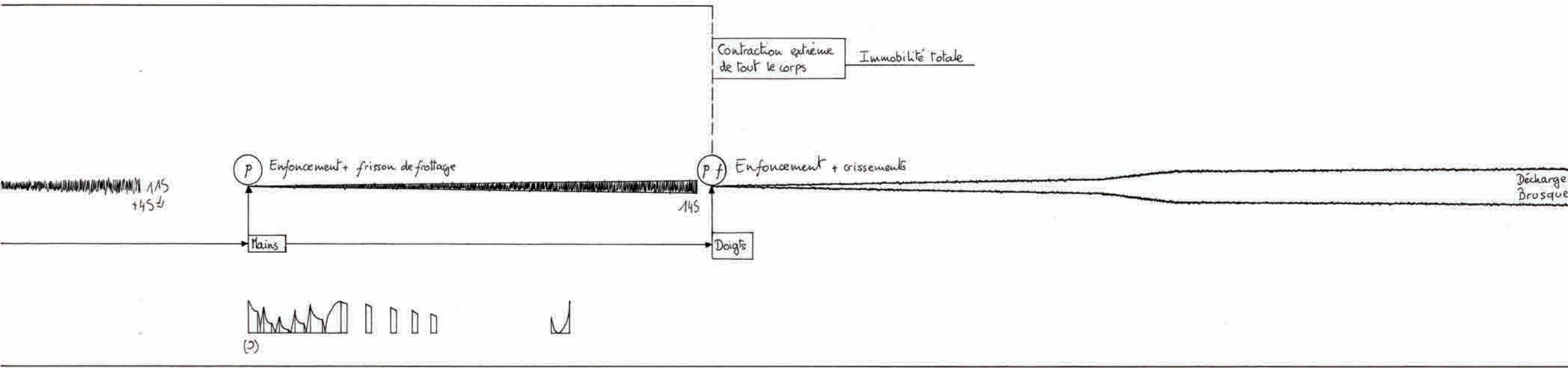

Perturbation 1

Crissant →

- feuille calque étalée sur peau

Perturbation 2

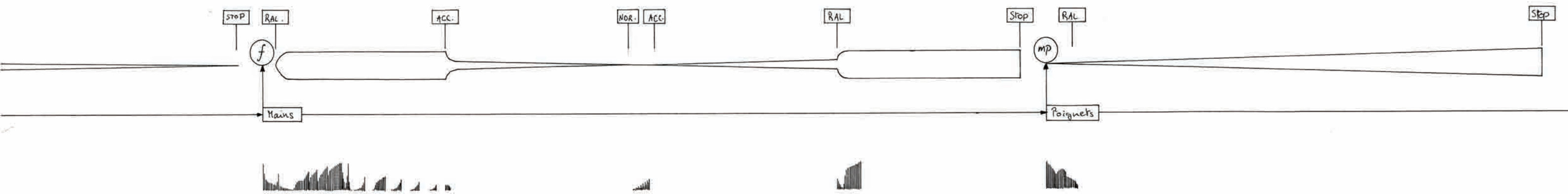
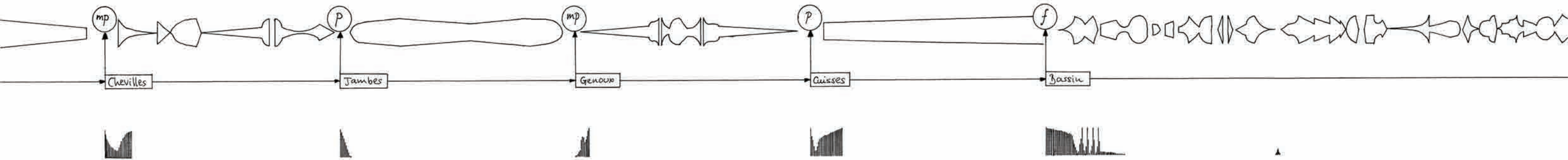
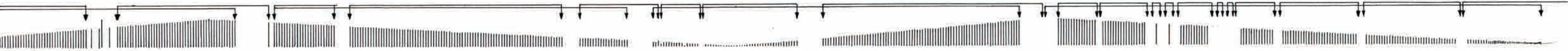

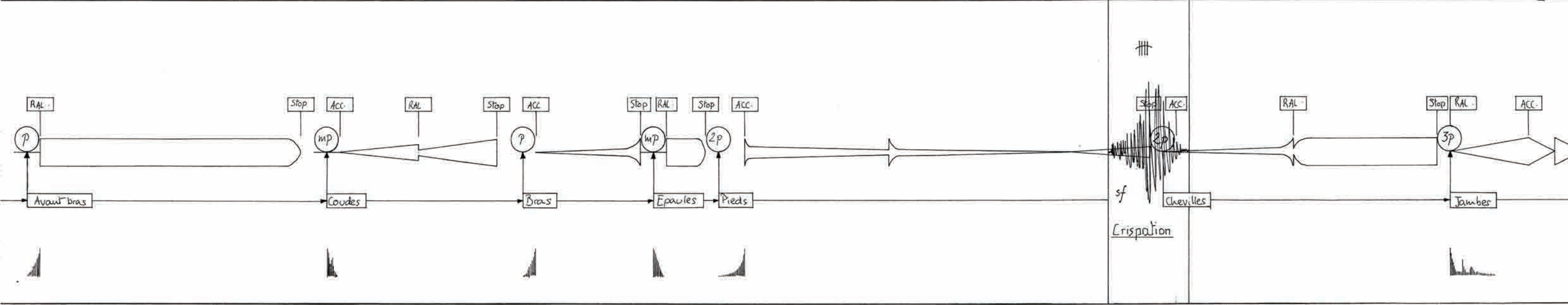
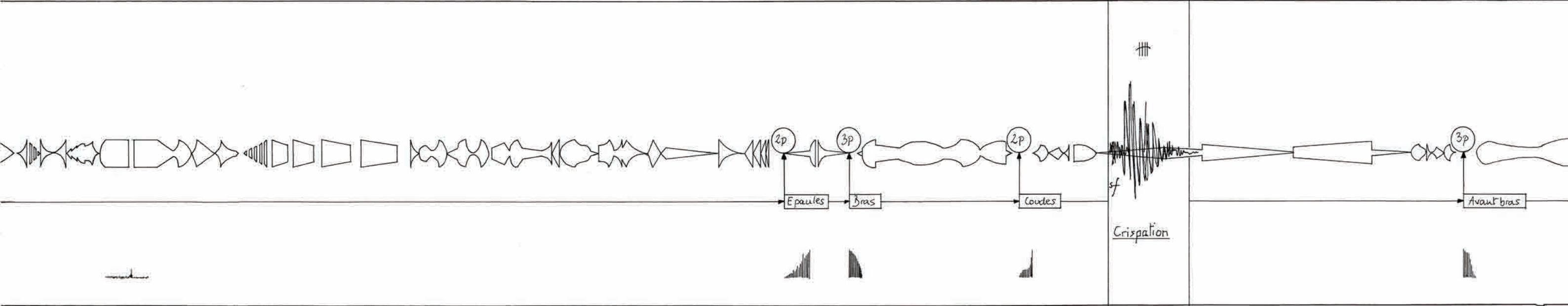
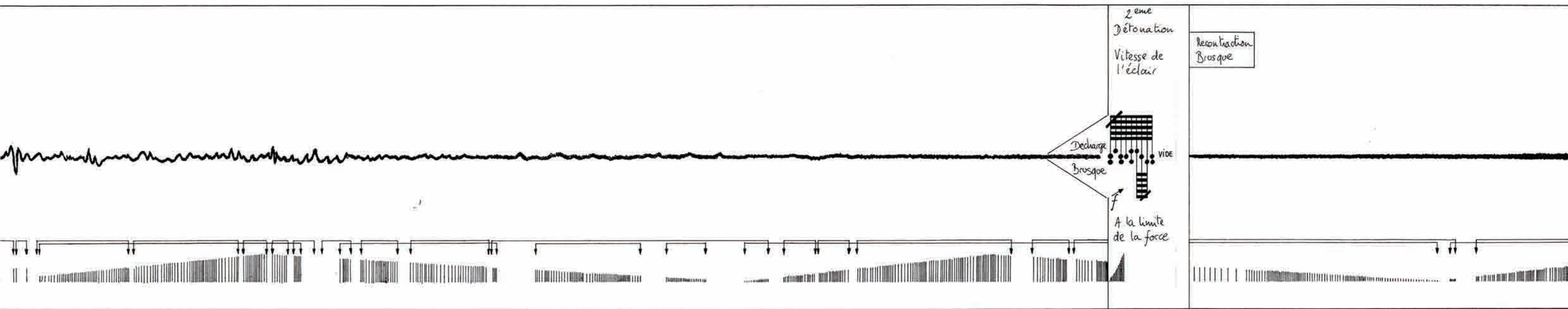



Perturbation 3

Perturbation 4

3<sup>ème</sup> Détonation  
Vitesse de l'éclair

Recontraction Brusque

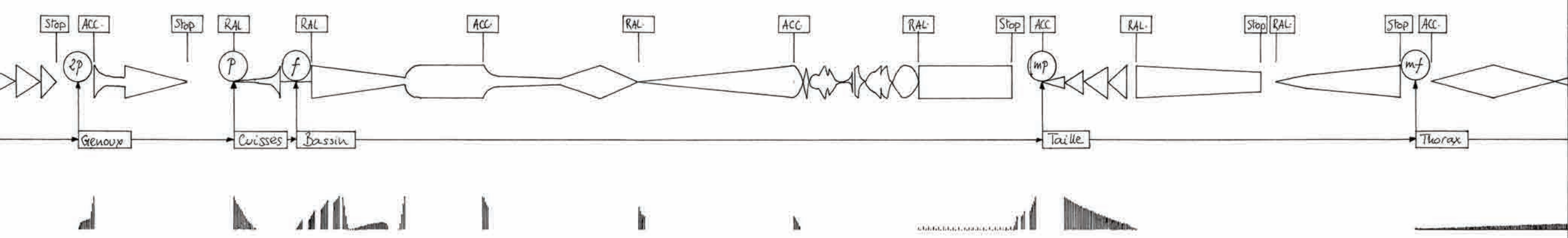
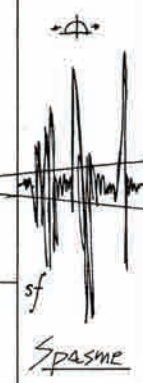
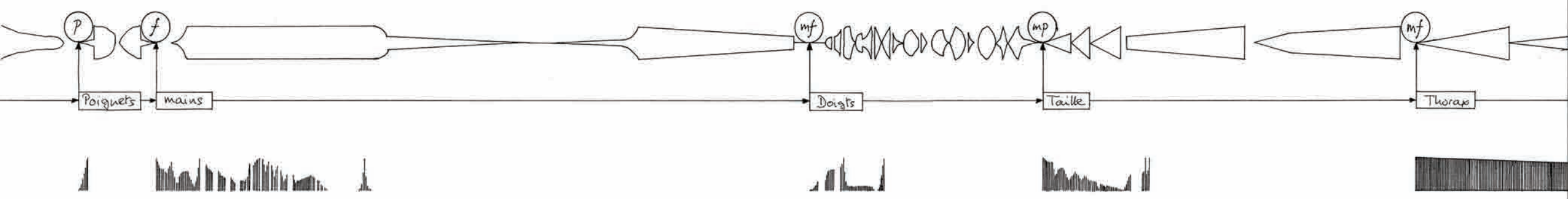
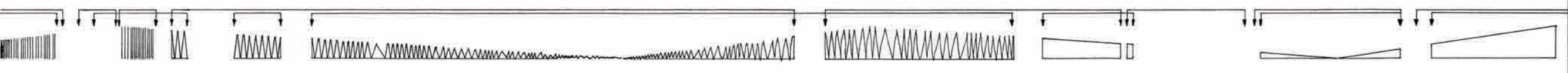
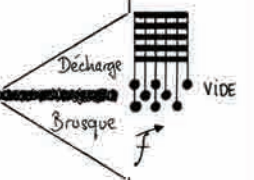

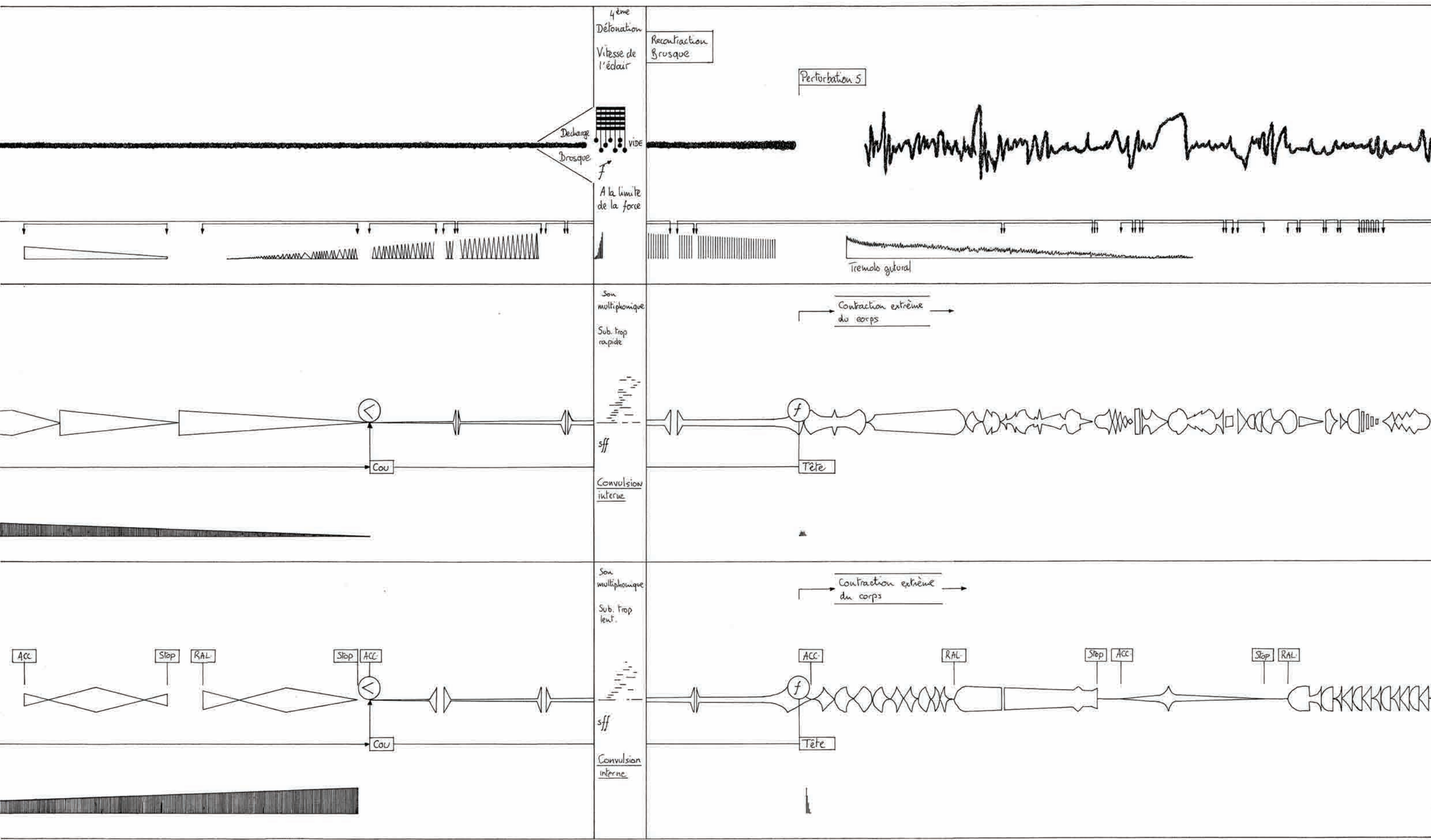

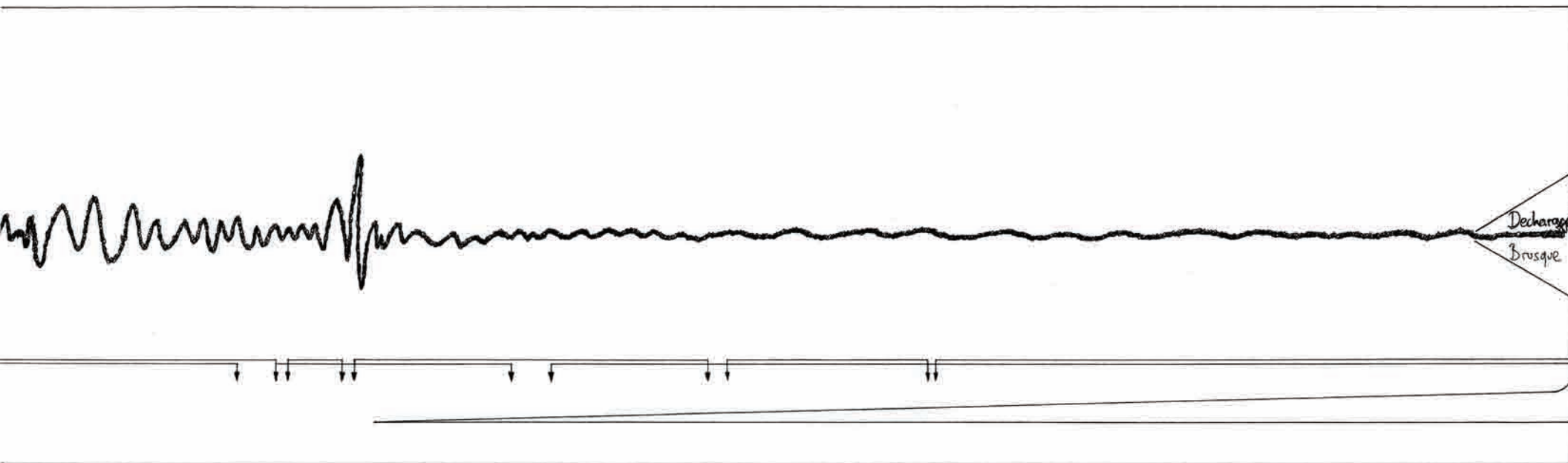

5<sup>ème</sup>  
Détonation  
A la vitesse  
de l'éclair

Decharge  
Brusque

VIDE

F

A la limite  
de la force

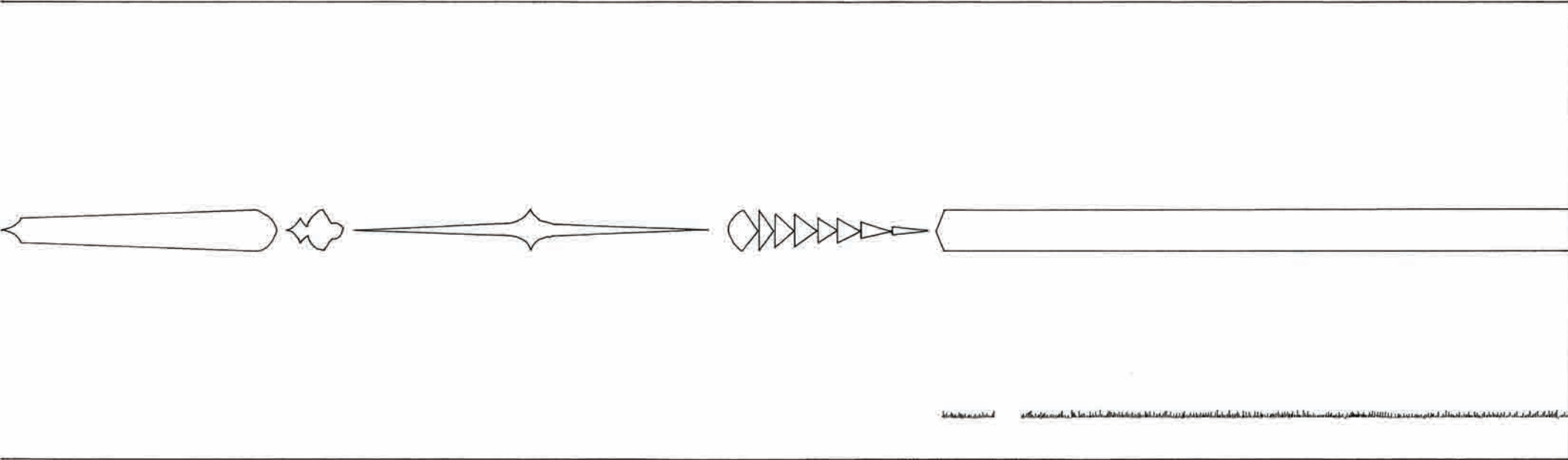
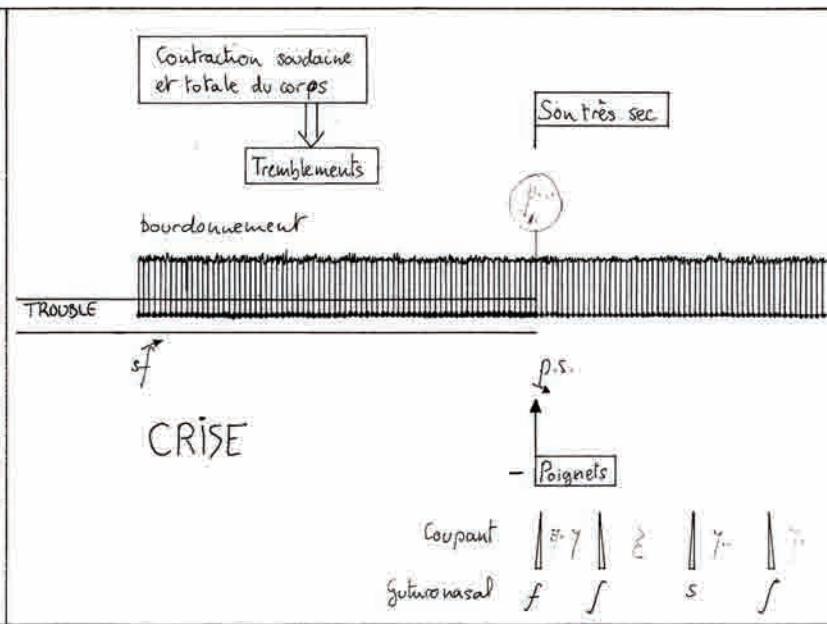

Son multiphonique

Convulsion externe

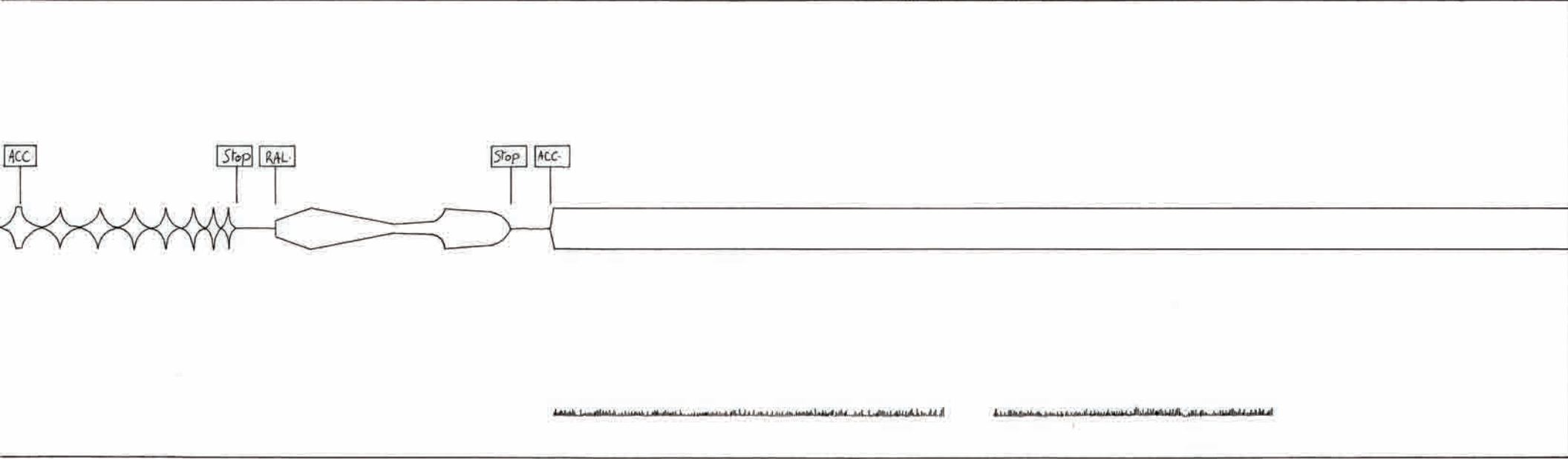
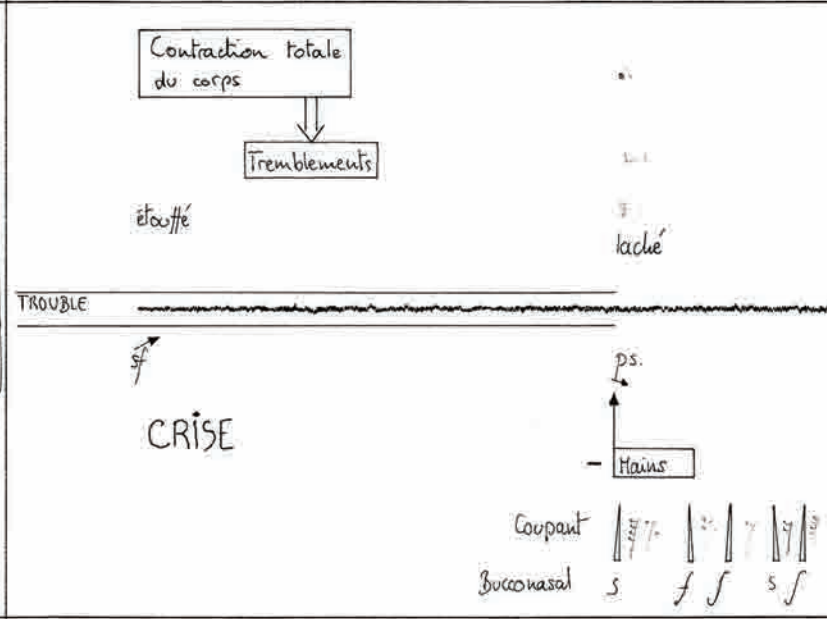

Son multiphonique

Convulsion externe

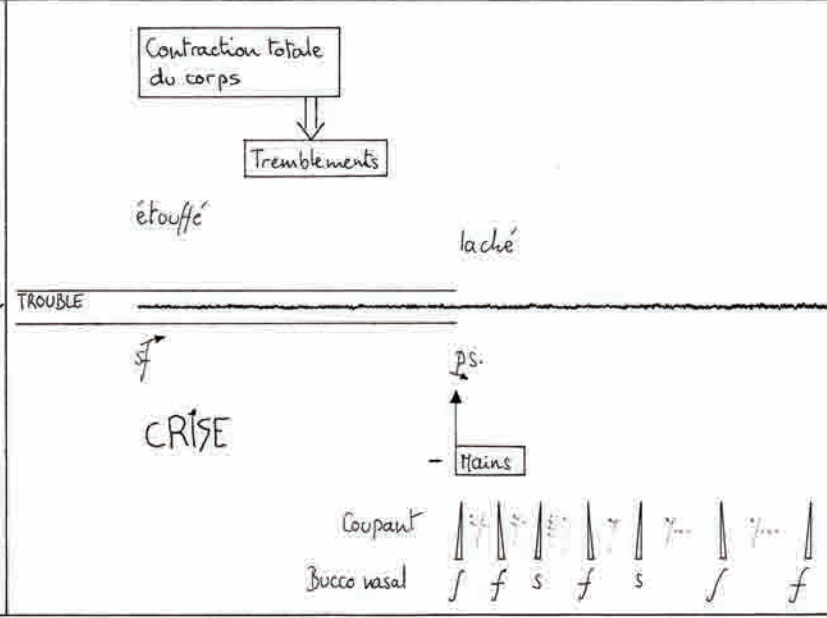

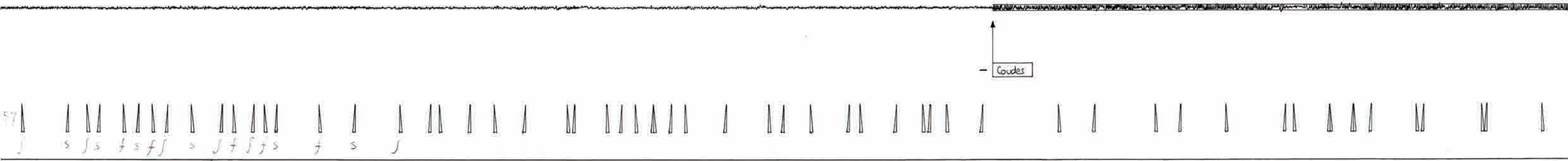
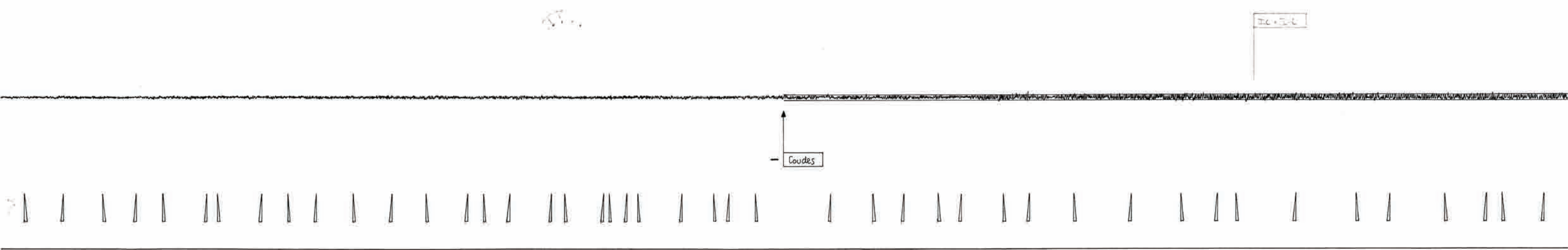
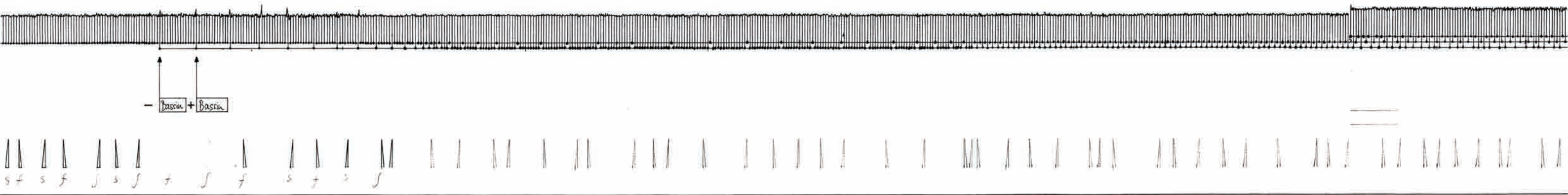

Flow  $\frac{1}{2}$  inch

(1/2)

1/2

1/2

2/

2/

coupart

100

100

100

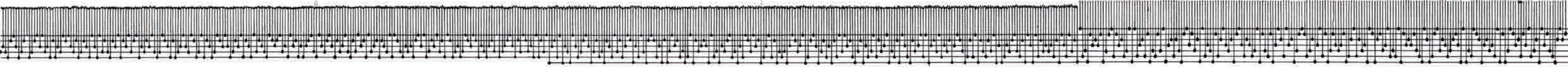

100

100

100



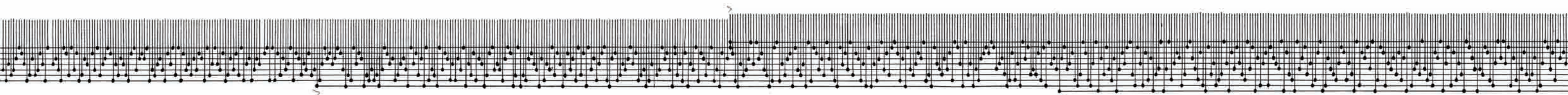

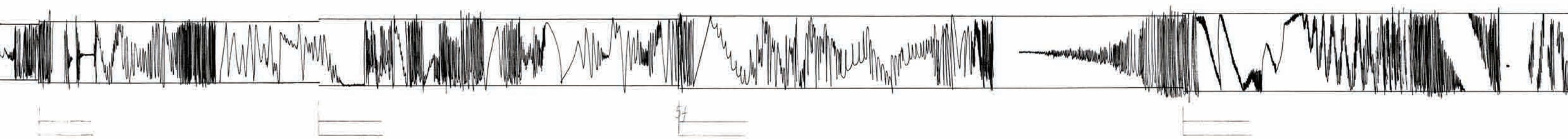
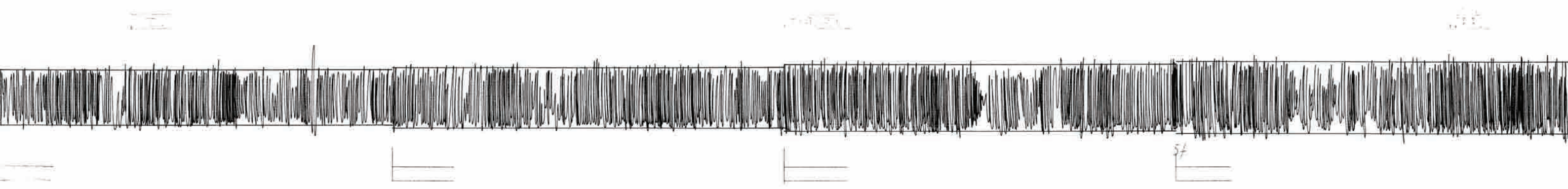
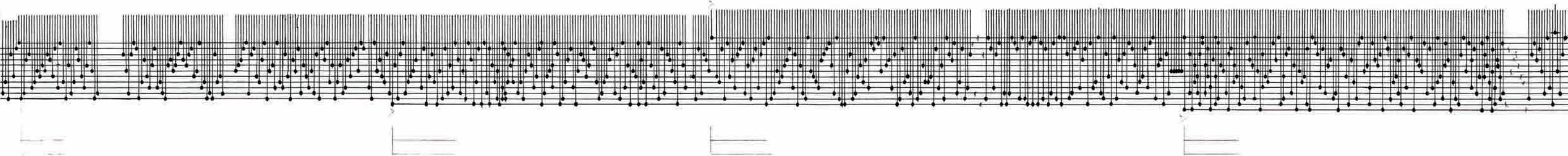



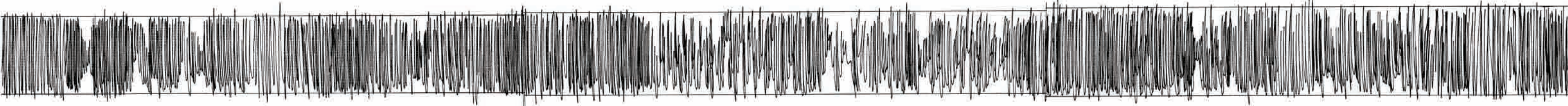
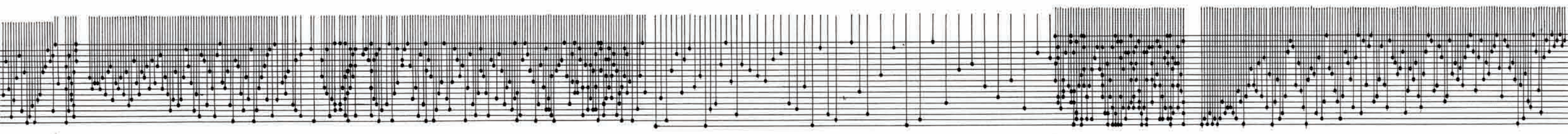

11.10

11.10

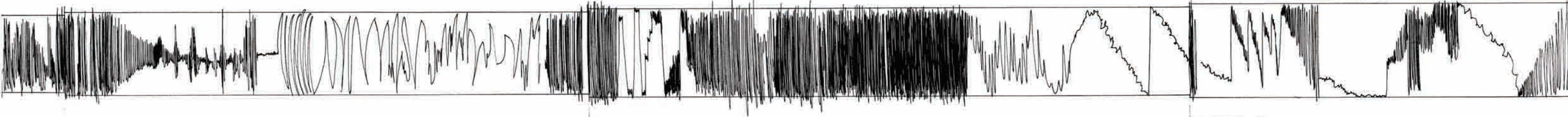

A musical score for the first staff, featuring a complex rhythmic pattern of notes and rests on a five-line staff. The notes are densely packed, creating a textured, almost continuous line of sound. There are several horizontal lines below the staff, possibly indicating fingerings or other performance instructions.

*Gutural archi-forcé*

A musical score for the second staff, showing a dense, textured pattern of notes and rests. The notes are very close together, creating a thick, almost solid block of sound. There are several horizontal lines below the staff, possibly indicating fingerings or other performance instructions.

*Gutural archi-forcé*

A musical score for the third staff, featuring a dense, textured pattern of notes and rests. The notes are very close together, creating a thick, almost solid block of sound. There are several horizontal lines below the staff, possibly indicating fingerings or other performance instructions. Handwritten annotations are present above the staff: "III+IV", "III+IV", and "ACC/FULL".

*Gutural archi-forcé*

4f

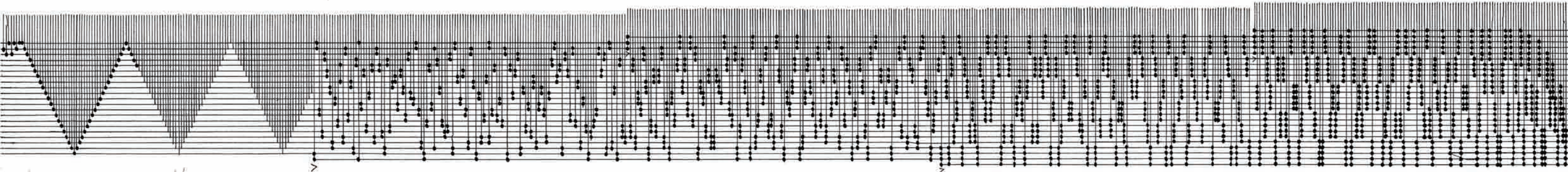

dans tube métal long  
 de détresse et de désespoir déclirant  
 sf subito

reverb.  $\emptyset$

Jusqu'au dernier râle  
 → max.

3f

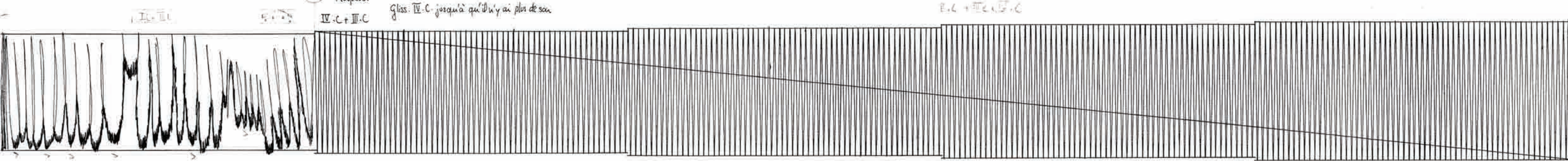

Rapeux  
 IV.C. + III.C. gliss. IV.C. jusqu'à qu'il n'y ai plus de son

E.C. + III.C.

dans tube métal long  
 de détresse et de désespoir déclirant  
 sf subito

reverb.  $\emptyset$

Jusqu'au dernier râle  
 → max.

4f

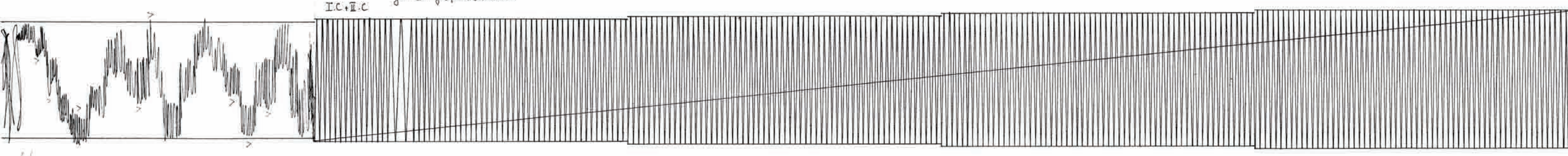

Rapeux  
 I.C. + II.C. gliss. I.C. jusqu'à sa cassure

dans tube métal long  
 de détresse et de désespoir déclirant  
 sf subito

reverb.  $\emptyset$

Jusqu'au dernier râle  
 → max.

Sub. son sourd, lourd, étouffé

Sub. ①

Tremblement extrême

la IV<sup>e</sup> corde est retendue par palier

voir additif

Sub. ①

2 archets



Décontraction subite  
et totale

les sons glissent de partout: legatissimo

The image displays a handwritten musical score on a page with a vertical ruler on the left. The score is composed of several systems of musical notation, including notes, rests, and dynamic markings. The notation is written in black ink on white paper. The score is organized into several sections, each enclosed in a large, hand-drawn oval or loop. The notation includes various note values, such as quarter notes, eighth notes, and sixteenth notes, as well as rests and slurs. Dynamic markings like *p*, *mp*, *ps.*, *f*, *mf*, and *ps.<mp<f* are used throughout. There are also some numerical annotations, such as  $\frac{1}{16}$ ,  $\frac{1}{9}$ ,  $\frac{1}{5}$ ,  $\frac{1}{7}$ ,  $\frac{1}{3}$ , and  $\frac{1}{4}$ , which likely refer to note values or time signatures. The overall style is that of a composer's sketch or a personal study score, with a focus on musical phrasing and dynamics. The text at the top left, "Décontraction subite et totale", and the text at the top center, "les sons glissent de partout: legatissimo", provide context for the musical ideas being explored. The ruler on the left side of the page is marked in centimeters, with millimeter increments.

Mov. instable

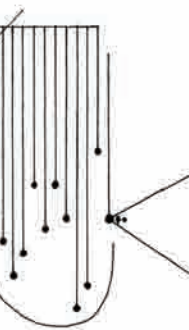
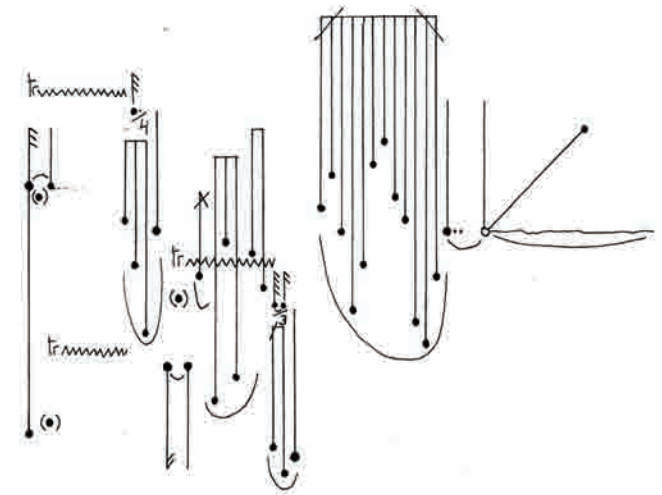
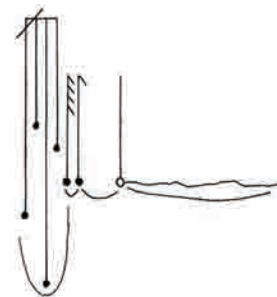
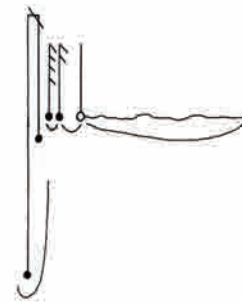
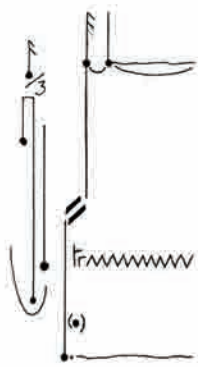
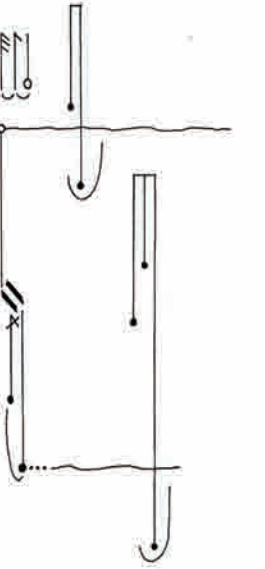
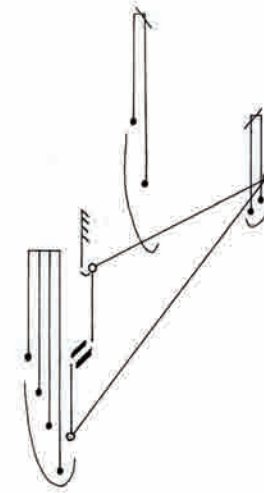
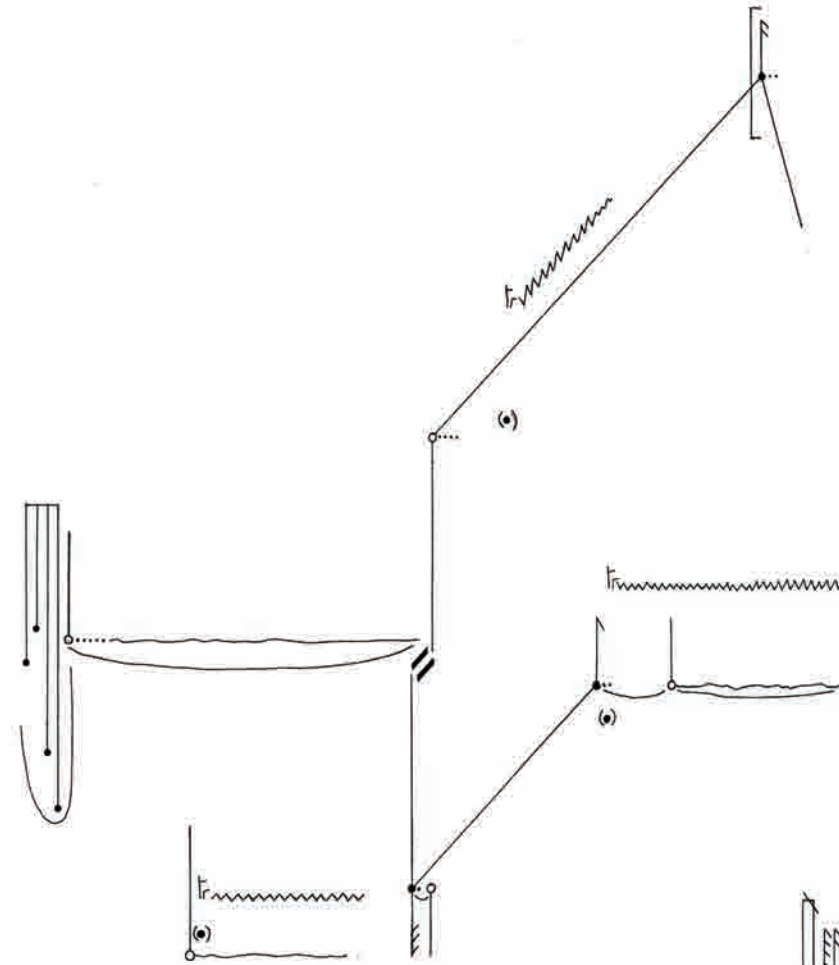
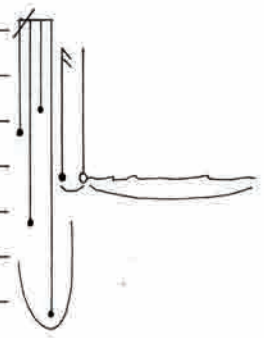
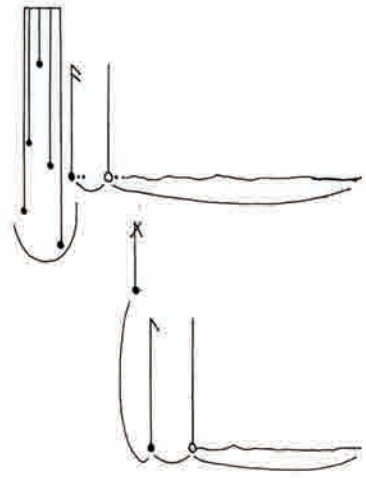
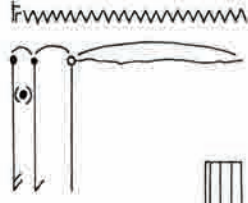

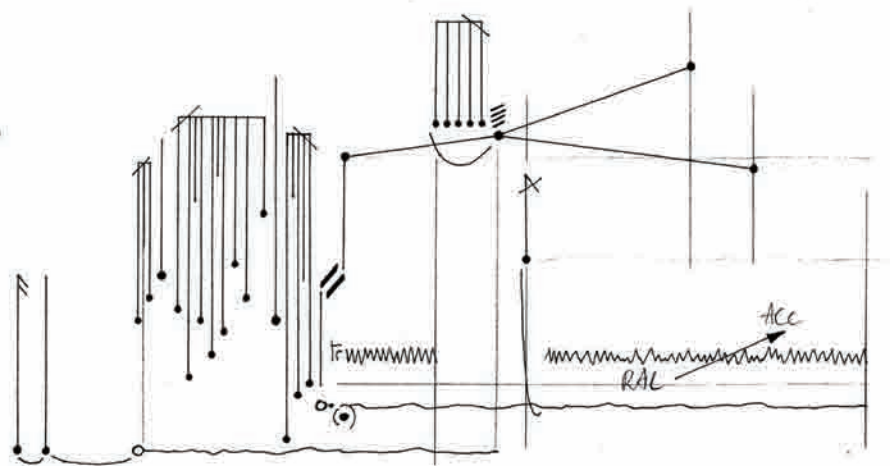
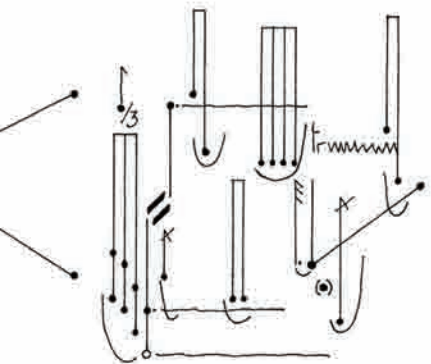
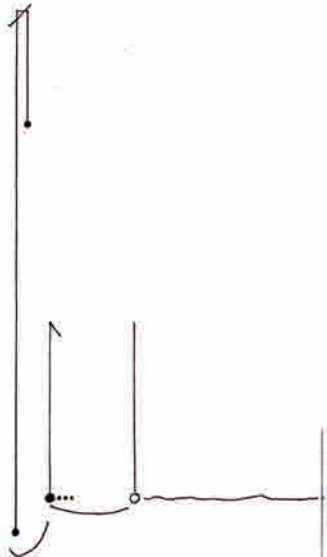
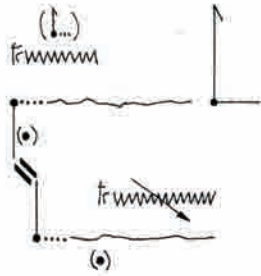



Handwritten notes or a list of numbers along the left margin.

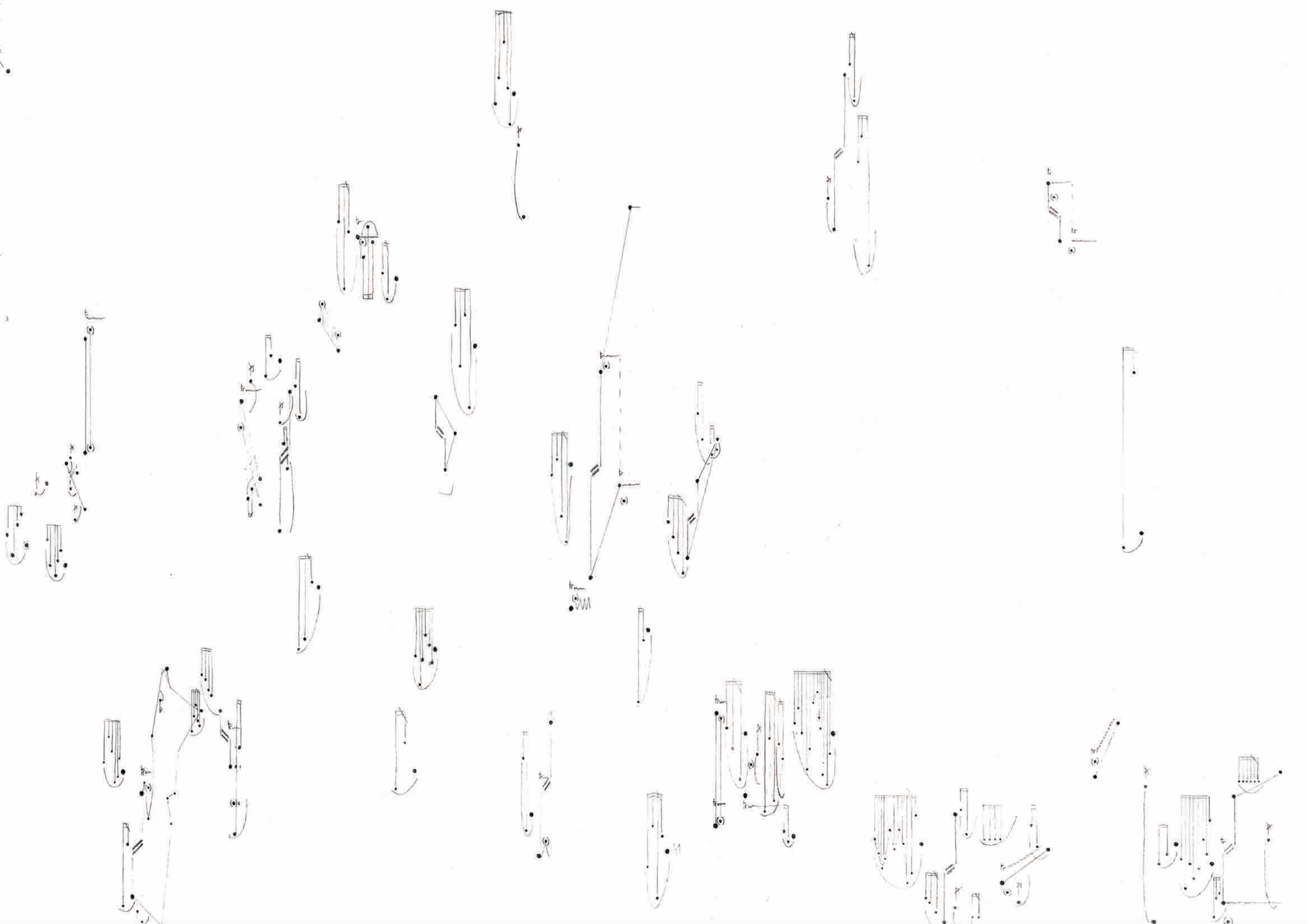

M.C.

Frottages sur vitres

HALLUCINANCE DE DÉTENSION

M.C.

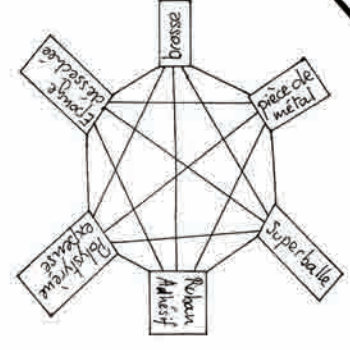

Frottages sur vitres

M.C.

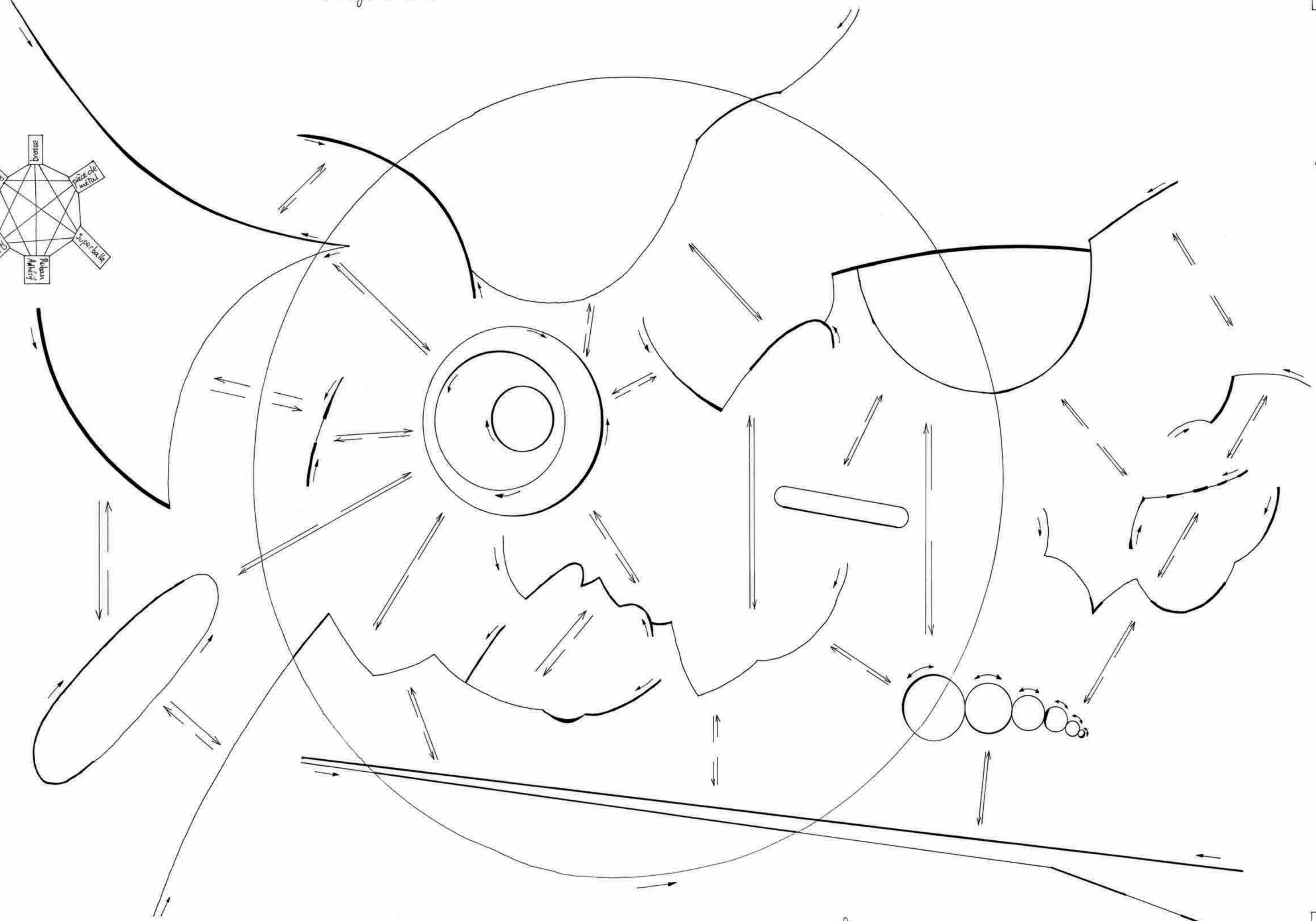

Frottages sur vitres

M.C.

Frottages sur vitres

Recontraction progressive et totale  
 Prestissimo ACC.  
 Enfoncement

couplant

frisson de frotage

couplant

Enfoncement + frisson de frotage

*f* *mp* *f* *p*

**FLASH**

Son très lointain  
 Son harmonique pur lisse  
 Sourde.

ral. léger serrement  
 a tempo via sourd.  
 ral. Angoisse  
 acc.  
 a tempo Ondulations  
 le son enlève son enveloppe  
 Serrement angérisé

Recontraction soudaine et totale  
 ACC.  
 Hyper claquage de cordes

*ps.* *3p* *2p* *2f* *3f* *4f*

*f*

Sala d'har max

**FLASH**

Son absent  
 Son harmonique pur lisse  
 Sourde.

via sourd.

le son se remplit

le son enlève son enveloppe

Recontraction soudaine et totale  
 ACC.  
 Hyper claquage de cordes

*ps.* *2p* *2f* *3f* *4f*

*f*

Trémolo de la langue

fall Derive dans les rapides chute noyade dans le vide

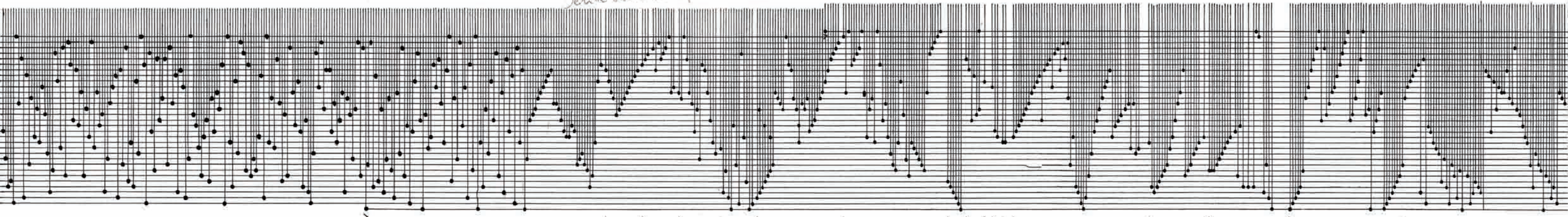

↓ (a)  
 ↓ (a)?  
 ↓ (a)  
 ↓ (a)  
 ↓ (a)  
 ↓ (a)  
 ↓ (a)  
 ↓ (a) (a) (a) (a) (a) (a)  
 ↓ (a) (a) (a) (a) (a) (a)

dytiation, n... exha...

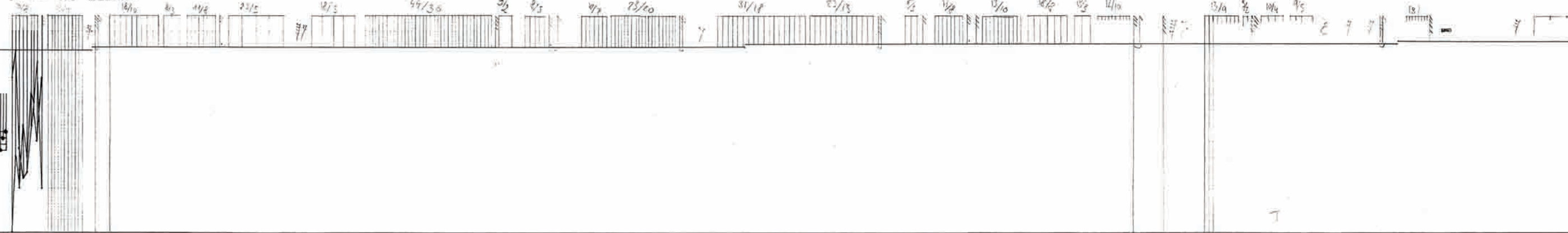

leu... de la... existence

Tando gal... salve

Un cascadeur plongeant à travers une vitre de 2m de côté (provoque l'arrêt brusque)

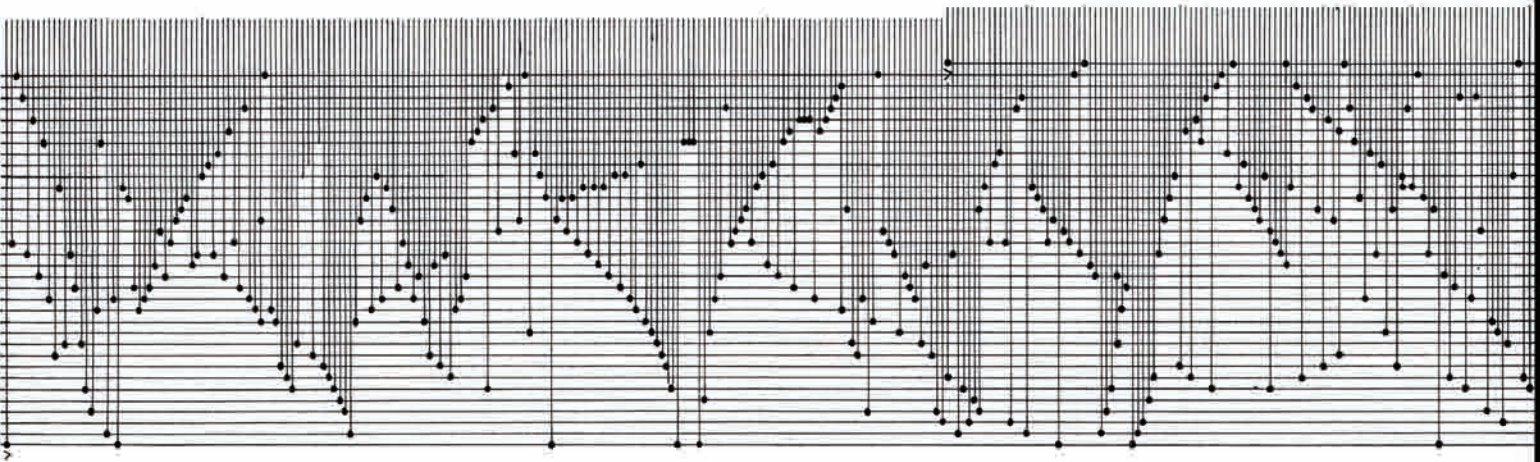

PARALYSIE HYSTERIQUE

Anémie astasique (entre la vie et la mort)



SOUDAIN LA PLUIE S'EST MISE A TOMBER

PARALYSIE HYSTERIQUE

Anémie astasique (entre la vie et la mort)



PARALYSIE HYSTERIQUE

Anémie astasique (entre la vie et la mort)

NOIR VIDE 3"

Top progressif

Tout respand

GRIS CLAIR

Rougeux

BLANC SOUS LE HAIR  
ROSE-BLEUE

Environ trois minutes après le début de la pluie, tout en jouant, 3 personnages en blancs apparaissent aux 3 coins opposés de la salle en poussant chacun devant eux une grande vitre jusqu'au centre de la salle. A un moment 3 gongs très graves cachés doubles les 3 grandes vitres.

Les 3 gongs disparaissent, les 3 joueurs de vitre s'éloignent en sens inverse.

second souffle

Pendant la pluie; apparition, disparition: passage

Très doux, très lent sauf aux rencontres incomplètes, autre son.

37 + 77 =

53 + 77 =

29 + 77 =

le 1<sup>er</sup> novembre 1982

APRIL